

HUS/HHUS/HGUS

Double-Shear Face-Mount Hangers



This product is preferable to similar connectors because of (a) easier installation, (b) higher loads, (c) lower installed cost, or a combination of these features.

See hanger tables on pp. 145–152.

These hangers are designed for applications where higher loads are needed (also see HUC and HUCQ).

All hangers in this series have double-shear nailing. This innovation distributes the load through two points on each joist nail for greater strength. It also allows the use of fewer nails, faster installation and the use of common nails for all connections. (Do not bend or remove tabs.)

Material: HHUS — 14 gauge; HGUS — 12 gauge; HUS 2x and 1¾ sizes — 16 gauge; HUS — 14 gauge

Finish: Galvanized. Some products available in stainless steel or ZMAX®. See Corrosion Information, pp. 12–15.

Installation:

- Use all specified fasteners; see General Notes.
- Do not use double-shear hangers with I-joists.
- Nails must be driven at an angle through the joist or truss into the header to achieve the table loads.
- Not designed for welded or nailer applications.
- See p. 22 for alternate fastener sizes and load adjustments.

Options:

- HUS cannot be modified
- Other sizes available; contact Simpson Strong-Tie for details

HHUS — Sloped and/or Skewed Seat

- HHUS hangers can be skewed to a maximum of 45° and/or sloped to a maximum of 45°
- For skew only, maximum allowable download is 0.85 of the table load
- For sloped only or sloped and skewed hangers, the maximum allowable download is 0.65 of the table load
- Uplift loads for sloped/skewed conditions are 0.72 of the table load, not to exceed 2,475 lb.
- The joist must be bevel-cut to allow for double shear nailing

HGUS — Skewed Seat

- HGUS hangers can be skewed only to a maximum of 45°. Allowable loads are:

HGUS Seat Width	Carried Member End Condition			
	Square Cut		Bevel Cut	
	Uplift	Download	Uplift	Download
W < 2"	0.46	0.62	0.46	0.72
2" < W < 6"	0.41	0.46	0.41	0.85
6" < W < 6.75"		0.40		
6.75" < W < 7.25"	Not allowed	Not allowed		

Codes: See p. 11 for Code Reference Key Chart

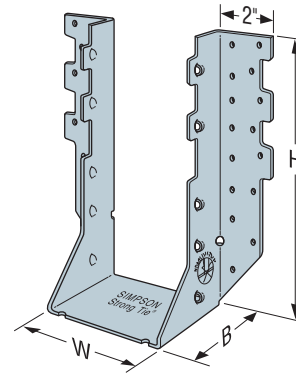

✓ HHUS410

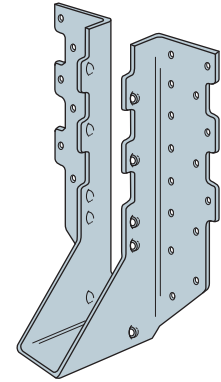

✓ HUS181-10

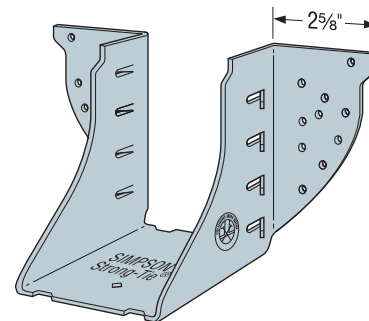

✓ HGUS46

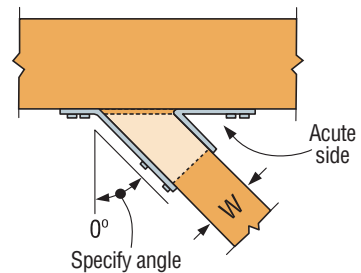

Top View HHUS Hanger Skewed Right
(joist must be bevel cut)