

# MGT/HGT

## Girder Tiedowns

The MGT and HGT series are girder tiedowns for moderate to high load applications that are typically installed prior to roof sheathing. The MGT can wrap over the heel and is anchored on one side of the truss. The HGT straddles the heel and anchors on both sides of the truss. The HGT is field-adjustable, making it suitable for trusses with top chord slopes up to 8/12. The HGT is available in sizes for two-, three- and four-ply widths.

**Material:** MGT — 12 gauge; HGT — 7 gauge

**Finish:** MGT — galvanized; HGT — Simpson Strong-Tie gray paint

**Installation:**

- Use all specified fasteners; see General Notes
- When the HGT-3 is used with a two-ply girder or beam, shimming is required and must be fastened to act as one unit
- Attach to grouted concrete block with a minimum one #5 rebar horizontal in the top lintel block
- **MGT — May be installed with straps straight vertically on minimum 5½"-wide truss web, or with straps wrapped over truss heel. For wrapped installations, install minimum of six nails into the face of the roof member on the same side as MGT base.**
- See pp. 284–285 for wood applications

**Codes:** See p. 11 for Code Reference Key Chart

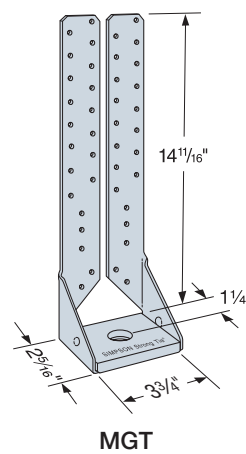

**MGT**

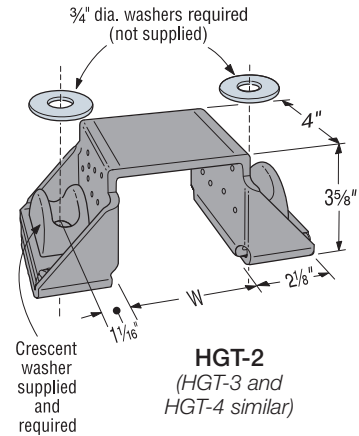

**HGT-2**  
(HGT-3 and HGT-4 similar)

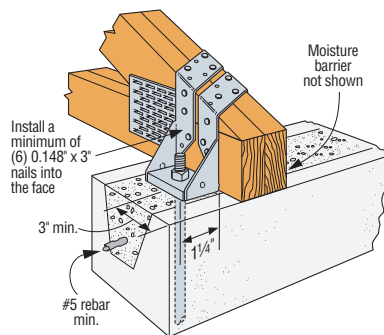

**Typical MGT Installation**

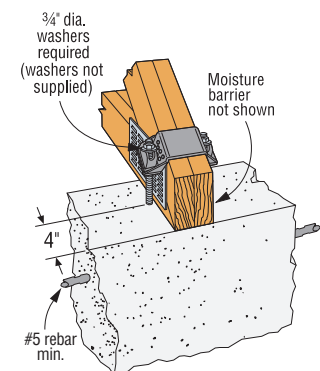

**Typical HGT-2 Installation into Concrete**

| Model No. | W (in.) | O.C. Dimension Between Anchors (in.) | Fasteners (in.) |                           | Allowable Uplift Loads |              | Code Ref.   |
|-----------|---------|--------------------------------------|-----------------|---------------------------|------------------------|--------------|-------------|
|           |         |                                      | Girder          | Concrete and GFCMU Anchor | DF/SP (160)            | SPF/HF (160) |             |
| MGT       | 3¾      | —                                    | (22) 0.148 x 3  | (1) ½                     | 4,365                  | 3,750        | IBC, FL, LA |
| HGT-2     | 3⅝      | 5¾                                   | (16) 0.148 x 3  | (2) ¾                     | 10,345                 | 6,485        |             |
| HGT-3     | 4⅝      | 7¾                                   | (16) 0.148 x 3  | (2) ¾                     | 10,440                 | 9,035        |             |
| HGT-4     | 6⅝      | 9                                    | (16) 0.148 x 3  | (2) ¾                     | 11,395                 | 9,250        |             |

1. Attached members must be designed to resist applied loads.
2. Concrete shall have a minimum compressive strength of  $f'_c = 2,500$  psi.
3. Grout-filled CMU (GFCMU) shall have a minimum compressive strength of  $f'_m = 1,500$  psi.
4. To achieve the loads listed for the MGT and HGT, install SET-XP® anchoring adhesive anchorage into a 8"-wide concrete tie-beam or grouted and reinforced CMU **bond beam** with a minimum embedment depth of 12". Vertical reinforcement may be required to transfer the loads per designer. Alternate anchorage may be determined by designer.
5. Allowable loads have been increased for wind or earthquake loading with no further increase allowed. Reduce where other loads govern.
6. **MGT allowable loads are based on installation on a minimum 2-ply wood truss or beam. For single-ply applications, install MGT with (22) 0.148" x 1.5" nails for uplift of 3,165 lb. (DF), 3,275 lb. (SP) and 2,720 lb. (SPF/HF).**
7. **Fasteners:** Nail dimensions are listed diameter by length. See pp. 21–22 for fastener information.