

LGT/MGT/VGT/HGT

Girder Tiedowns

The LGT, MGT, VGT and HGT are girder tiedowns for moderate- to high-load capacity applications. The LGT and VGT are also suitable for retrofit applications.

LGT connectors provide a low-profile connection to the studs for easy installation of drywall. Simple to install and can be installed on the inside or outside of the wall. LGT connectors also provide exceptional bearing enhancement for heavy download applications.

The Variable Girder Tiedown (VGT) is a higher capacity alternative to the LGT and MGT for girder trusses. It attaches with Strong-Drive® SDS Heavy-Duty Connector screws to the side of truss and features a predeflected crescent washer that allows it to accommodate top chord pitches up to 8/12. The VGT is also available with one flange concealed for attachment to trusses with no tail.

The HGT offers the highest uplift capacity for girders and can be installed on trusses and beams with top chord slopes up to 8/12.

Material: HGT, VGT — 7 gauge; LGT2 — 14 gauge; MGT, LGT3, LGT4 — 12 gauge

Finish: HGT — Simpson Strong-Tie gray paint; LGT, MGT, VGT — galvanized

Installation:

- When the HGT-3 is used with a 2-ply girder or beam, shimming is required. Fasten shim to act as one unit.
- Before installing fasteners, ensure LGT3-SDS2.5 makes complete contact with bottom of truss.
- Strong-Drive SDS Heavy-Duty Connector screws included with LGT3, LGT4 and VGT series.
- VGT — Can be installed on roof pitches up to 8/12 or on a bottom chord designed to transfer the load.
- VGT — Screw holes are configured to allow for double installation on a two-ply (minimum) truss.
- VGT — When installed on trusses with no overhangs, specify VGTR/L.
- VGT — Install washer component (provided) so that top of washer is horizontal as well as parallel with top-of-wall top plate.
- LGT3-SDS2.5 — The four large hexagon holes are intended for GFCMU and concrete applications.
- MGT — May be installed with straps straight vertically on minimum 5½"-wide truss web, or with straps wrapped over truss heel. For wrapped installations, install minimum of six nails into the face of the roof member on the same side as MGT base.
- See pp. 258–259 for masonry applications.

Codes: See p. 11 for Code Reference Key Chart

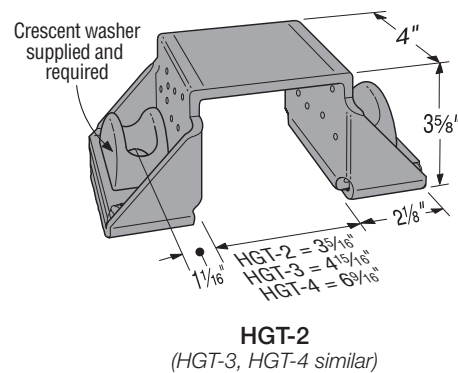
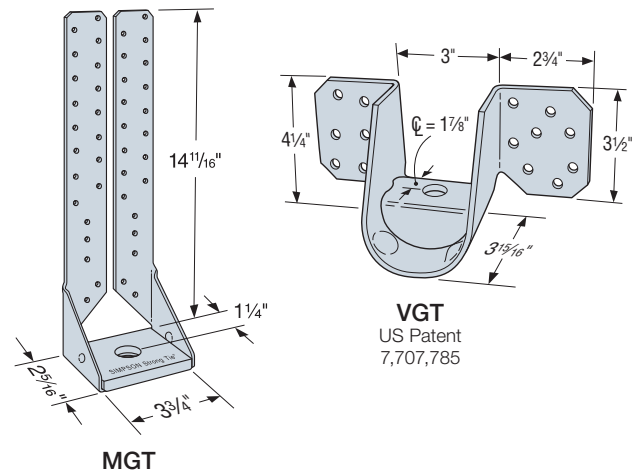
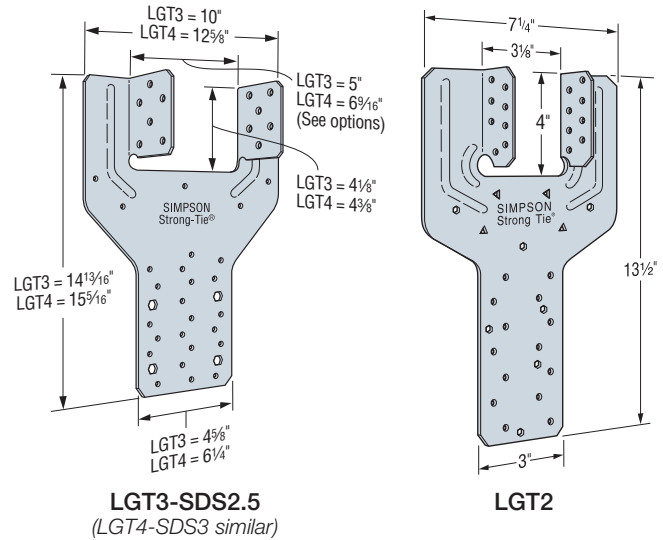

LGT/MGT/VGT/HGT

Girder Tiedowns (cont.)

These products are available with additional corrosion protection. For more information, see p. 14.

Model No.	Qty.	No. of Plies	O.C. Dim. Between Anchors (in.)	Fasteners (in.)		DF/SP Allowable Loads			SPF/HF Allowable Loads			Code Ref.
				Stud/Plate Nails or Anchor Diameter	Girder	Uplift (160)	F ₁ (160)	F ₂ (160)	Uplift (160)	F ₁ (160)	F ₂ (160)	
LGT2	1	2 ply	—	(14) 0.148 x 3¼	(16) 0.148 x 3¼	2,040	700	170	1,755	700	170	FL
	1	2 ply	—	(14) #9 x 1½" SD	(16) #9 x 1½" SD	2,465	700	170	2,125	700	170	
LGT3-SDS2.5	1	3 ply	—	(26) 0.148 x 3¼	(12) ¼ x 2½ SDS	3,480	795	385	2,505	795	385	
LGT4-SDS3	1	4 ply	—	(30) 0.148 x 3¼	(16) ¼ x 3 SDS	4,060	2,000	675	2,920	2,000	675	
MGT	1	1 ply min.	—	(1) ½	(22) 0.148 x 1½	3,165	—	—	2,720	—	—	IBC, FL, LA
	1	2 ply min.	—	(1) ½	(22) 0.148 x 1½	4,365	775	525	3,750	775	525	
VGT	1	2 ply min.	—	(1) ½	(16) ¼ x 3 SDS	4,940	1,185	590	3,555	1,185	590	
	2	2 ply min.	—	(2) ½	(32) ¼ x 3 SDS	7,185	1,185	590	5,170	1,185	590	
	2	3 ply min.	—	(2) ½	(32) ¼ x 3 SDS	8,890	1,185	590	6,400	1,185	590	
VGTR/L	1	2 ply min.	—	(1) ½	(16) ¼ x 3 SDS	2,225	650	630	1,600	650	630	
	2	2 ply min.	—	(2) ½	(32) ¼ x 3 SDS	5,545	650	630	3,990	650	630	
HGT-2	1	2 ply	5¾	(2) ½	(16) 0.148 x 3	10,345	—	—	6,485	—	—	
HGT-3	1	3 ply	7¾	(2) ½	(16) 0.148 x 3	10,440	—	—	9,035	—	—	
HGT-4	1	4 ply	9	(2) ½	(16) 0.148 x 3	11,395	—	—	9,250	—	—	

- See pp. 266–267 for Straps and Ties General Notes.
- LGT2 — F₂ load requires installation of four 0.148" x 3¼" sinkers or four #9 x 1½" SD Connector screws (SD) in optional nail holes.
- LGT4 — F₂ load requires installation of seven 0.148" x 3¼" sinkers in optional nail holes.
- LGT4 — Uplift for DF/SP girder and SPF studs is 3,860 lb.
- LGT connectors can provide bearing enhancement loads for truss download reactions. For more information, refer to technical bulletin T-C-HTIEBEAR at strongtie.com.
- LGT2 installed with #9 x 1½" SD Connector screws (SD) will achieve double the uplift load when installed on opposite sides of the top plates, but on separate truss members. See typical back-to-back LGT2 installation detail. Lateral loads may not be doubled.
- Girder tiedowns installed on the outside of the wall require a 3½" overhang to achieve table loads.
- Strong-Drive® SDS Heavy-Duty Connector screws (SDS) may be installed through metal truss plates as approved by the Truss Designer, provided the requirements of ANSI/TPI 1-2014, Sections 7.5.3.4 and 8.9.2 are met (predrilling required through the plate using a ½" bit maximum).
- The allowable uplift load listed is for the girder tiedown and anchor rods only. The allowable uplift of the holddown or other anchorage must be checked.
- Fasteners:** Nail dimensions are listed diameter by length. SD and SDS screws are Simpson Strong-Tie® Strong-Drive screws. See pp. 21–22 for fastener information.

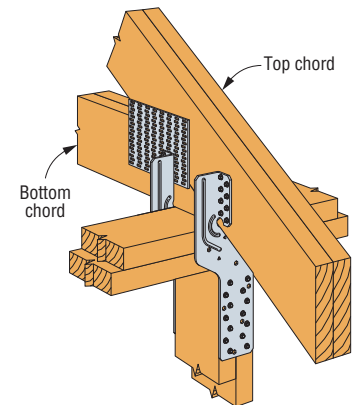

Typical LGT2 Back-to-Back Installation on Separate Truss Members

Install two LBP[®] washers on top of each crescent washer (total four ½" washers) for wood installation. All washers and crescent washers are required. Crescent washers are supplied.

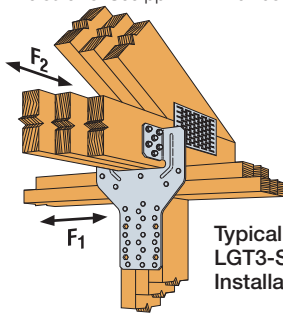

Typical LGT3-SDS2.5 Installation

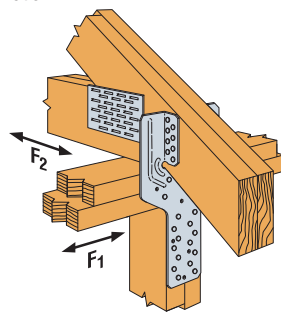

Typical LGT2 Installation

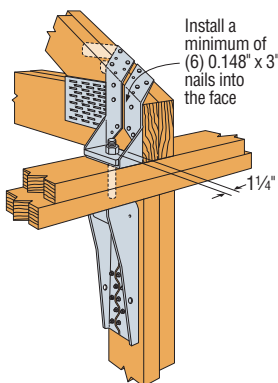

Typical MGT Installation with HDU4

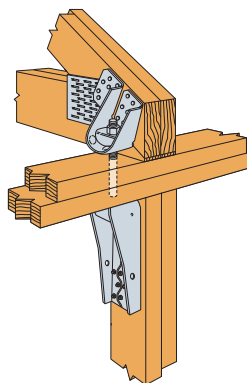

Typical VGTR Single Installation with HDU2

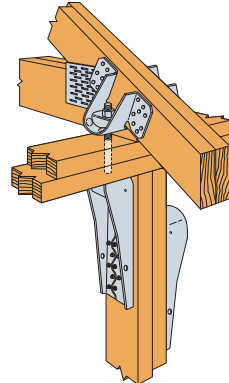

Typical VGT Double Installation with HDU4

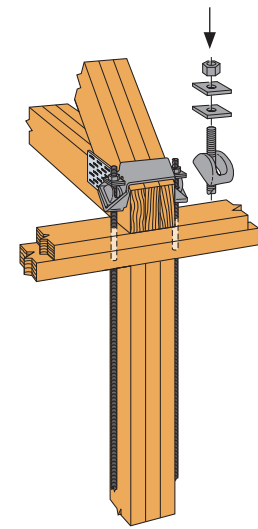

Typical HGT-3 Installation with Full-Height Threaded Rod